

BodenWärme



Floor Heating

Installation Manual

Loose Cable Heating

Technical advice available from Total Tiles:

Tel: 08444876548

Email: enquiries@totaltiles.co.uk



**IMPORTANT - PLEASE READ INSTRUCTIONS
FULLY BEFORE COMMENCING INSTALLATION**



IMPORTANT Do's and Don'ts.....	3
Materials required.....	4
Preparing the floor.....	5
Insulation board.....	6
Planning the layout of the heating.....	7
Testing of the heating.....	8
<i>(Before during & after installation)</i>	
Testing reference guide.....	9
Installation of the heating.....	10-11
Floor tile installation.....	12
Electrical considerations.....	13
Heating layout plan (Reference).....	14-15
Warranty.....	16
Consumer unit notice.....	17-18
Test results.....	17
Warranty registration (Return to retailer).....	19-20



WARNING

Ensure the instructions in this installation guide are followed carefully.





























Failure to do so will invalidate your warranty.

Incorrect installation or mishandling of the product can cause damage to the heating cable and could cause fire or electrical shock hazards resulting in personal injuries or damage to property.

It is Important that this heating system is only installed by a competent installer. The installer should be familiar and capable of the proper sizing, installation, construction & operation of floor warming systems.

As with all electrical projects governed by Part P regulations, all mains electrical connections must be undertaken by a certified electrician.

Total Tiles accept no liability, expressed or implied, for any loss or consequential damage suffered as a result of installations which in any way contravene the instructions that follow.

DO	DON'T
 Carefully read this instruction manual in full before commencing the installation.	 Install the heater(s) under any floor other than ceramic, porcelain or natural stone tiles.
 Contact us or a trained professional if you are unsure about any part of the installation before installing.	 Install heating onto unsuitable floor surfaces such as uncured concrete, Chipboard, MDF, OSB or floor boards.
 Test the heating system before, during and after installation.	 Cut or shorten the heating element at any time.
 Ensure the floor has been adequately strengthened, prepared and insulated.	 Leave any surplus heating under units or fixtures, the correct size MUST be used.
 Use the correct type of flexible levelling compound, tile adhesive and grout.	 Install on any surface other than internal floors, such as walls or stairs.
 Maintain a minimum gap between each heating wire of 50mm (2inches).	 Install without testing as detailed in this manual.
 Protect the circuit supplying the heater(s) with a 30mA RCD.	 Cross the heating wire over ANY other wire, including itself, other heating elements, the sensor wire or power lead.
 Ensure the end of the heating wire and the joint between the red heating wire & the black cold wire are both installed under the floor tiles.	 Connect more than one heater in series, only connect heaters in parallel.
 Ensure the heating elements are installed a minimum of 50mm away from conductive parts of the building, such as water pipes.	 Forget to install the floor temperature sensor. (Included in thermostat pack.)
 Take particular care when tiling not to damage the heating cable, a plastic adhesive trowel should be used.	 Install in room temperatures of less than 5°C (40°F)
 Draw a plan of where the heating wire is situated to avoid causing damage to the wire by any drilling after tiling (e.g. fixing of sanitary ware). Photos are recommended.	 Leave ANY heating without being FULLY ENCAPSULATED in flexible levelling compound or tile adhesive. Any air pockets around the heating cable will overheat causing damage to the wire.
 Avoid walking on heating during installation. If this is not possible use shoes with soft soles.	 Install floor sensor close to any other heat source or near doors or fixed items.
 Ensure all electrical connections are made by a certified electrician and all work complies with current IEE wiring regulations.	 Switch on the heating for 2 weeks following the completion of the tiling. This will allow the adhesive to fully cure.
 Use a Boden Wärme thermostat to control the heating.	 Install under fixed items such as sanitary ware, unless a minimum of a 60mm free flowing air gap can be maintained.

Materials required

To prepare the floor ready for the heating wire

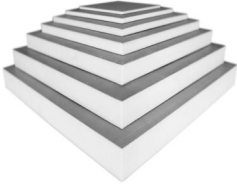

Insulation board for concrete floors

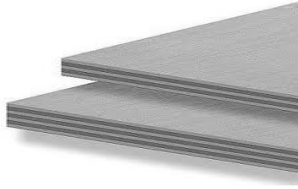

Marine or WBP plywood for stabilising wooden floors

To measure & mark out the layout of the floor



Tape Measure



Marker Pen



Multi-meter to test heater(s) before installation

To lay heater(s) and floor temperature sensor



Correct size Heat cable reel



Floor temperature sensor



Flexible sensor & Sensor cable conduit



Multi-meter to test heater(s) & sensor during installation



25mm Gaffer tape to fix wire to floor

OR



Metal strapping to fix wire to floor

Metal strapping can be adhered to floor with tacks, adhesive or double sided tape

To Connect the heater(s)



BodenWärme Thermostat



Suitable back box for thermostat. Single gang 45mm depth



30mA RCD protection for supply circuit



Meter to test heater & sensor after 4 fitting

Preparation of the floor base

All floors should be suitably prepared in accordance with all relevant local building regulations.

For UK installations, particular attention should be paid to the adherence to the British Standards for tiling—BS 5385 parts 3-5 and BS 8000 parts 2,3 & 9-11.

Failure to comply with the above standards will compromise the reliability of the heating system and invalidate the warranty.

The following information is intended only as a brief guide. If you are at all unsure about the suitability of the proposed floor for the installation of heating and tiles, a site survey should be conducted by a qualified professional.

Main considerations

- All floors must be sufficiently flat to permit the specified flatness of the finished tiling. Floors that are not sufficiently level should be made good with a suitable flexible levelling compound.
- Any deposits of oil, grease, old adhesive layers, efflorescence, laitance, dirt or other loose material must be removed by mechanical abrasion.
- Newly screeded / concrete floors must be allowed to cure for a minimum of 6 weeks before heating can be installed.
- Any movement issues in a concrete subfloor must be overcome with a solution such as Durabase CL++ Matting. (professional advice should be sought).
- Timber subfloors will require over boarding before the heating can be installed. The different options for this are shown below.
- Timber subfloors should have noggins fitted between the joists at 300mm centres.
- The edges & back of plywood boards should be sealed before fixing.
- A rigid base is essential - Fixing ply or backer board directly to joists will not provide a suitable stable floor finish for accepting tiles.
- Once the floor is adequately prepared and insulated a suitable primer can be applied. Refer to your tile adhesive / leveller product information to check requirements.

Floor Base	Fit heating onto directly	Overboard with 15mm WBP / Exterior / marine ply screwed (Countersunk) at 150mm centres	Overboard with Cement Coated Insulation Board 6/10mm. Fitted to manufactures specifications.	Overboard with a cement based tile backer board such as Hardibacker or “No More Ply”
Concrete / Screed base	✓ Inefficient high heat loss	N/A	✓ 10mm Recommended	N/A
Standard floor boards Screw & secure existing boards 1st	✗	✓ For 200w/m ² Output systems, Insulation board must be installed as well.	✗	✓ Less efficient than ply
Tongue & Groove floor boards *Must be fully interlinked & screwed well	✗	✓ As above	✓ *	✓ Less efficient than ply
22mm T&G Chipboard (Screwed to joists, NOT floated) Must comply with deflection levels of BS 5385	✗	✓ As above	✓	N/A

Floor preparation & Insulation

When installing heating onto a concrete floor, BodenWärme recommend the use of an insulation board. This board should be a good quality XPS sandwich board, each side being faced with a fibreglass mesh embedded into a cement polymer mortar.

Insulation boards reduce heat up times considerably, as displayed below. They significantly reduce heat loss to the concrete or wooden subfloor and can reduce running costs by up to 50%

Recently, a number of budget alternatives have emerged on the market. Until these have achieved European certification & have been approved by any major tile adhesive companies, BodenWärme are unable to guarantee installations made using these products.

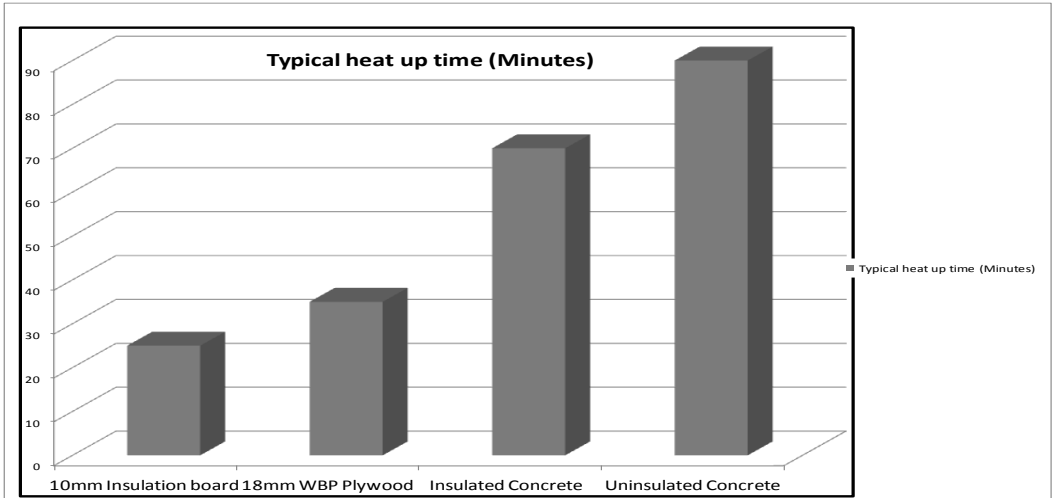

Examples of floor layers

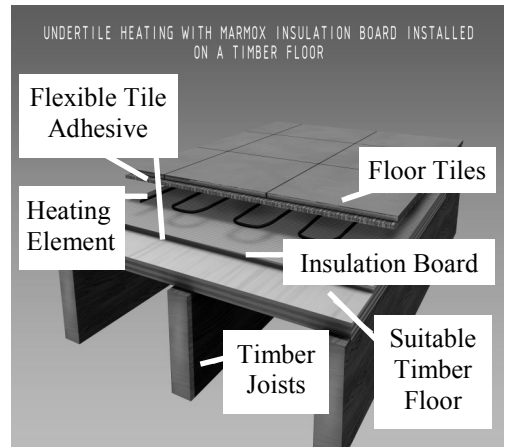
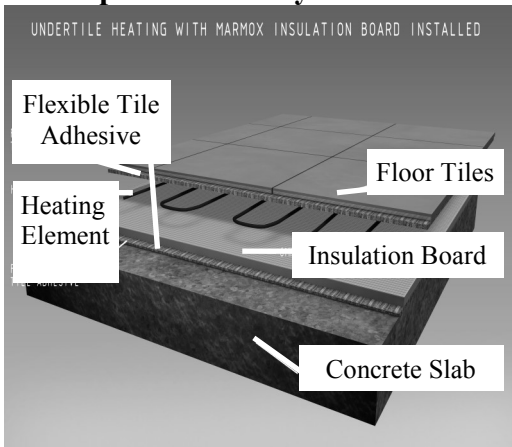

Insulation boards should be installed in accordance with the manufacturers instructions. To adhere insulation board onto concrete floors a flexible S1 grade adhesive should be used. To fix insulation board onto timber floors a flexible S2 grade adhesive should be used in conjunction with manufacturer approved screws & washers.

Planning your heating cable layout

Heat cable size

Before starting to install your heating it is vital to ensure you have the correct size heating cable to suit your room. Once the heating cable has been unravelled, unfortunately it cannot be returned.

The correct size cable is required as the wire **CANNOT** be cut, reduced or extended.

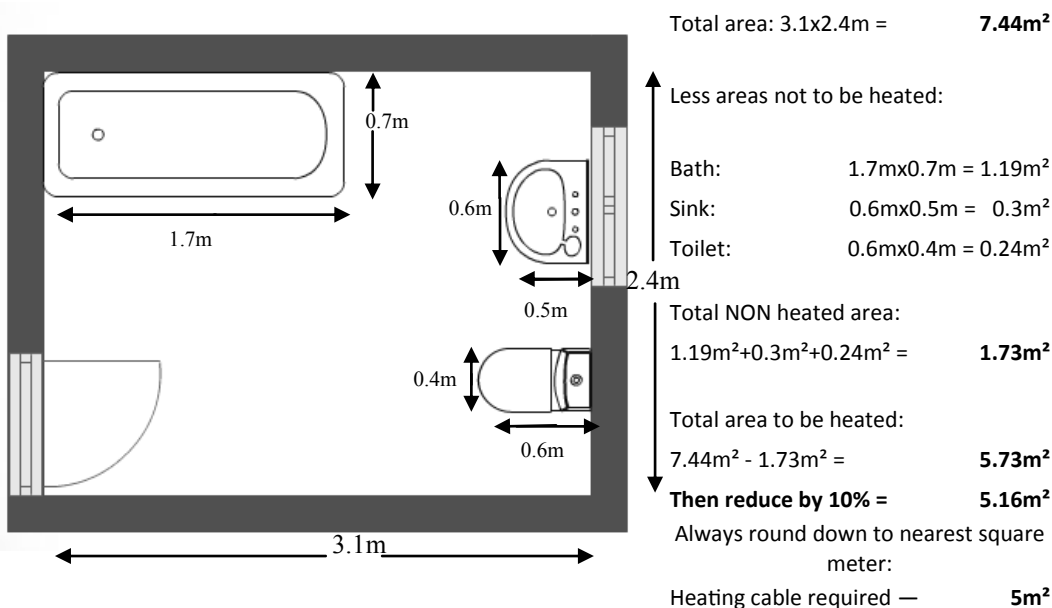

Heating should never be installed under fixed items such as showers or toilets as this can create hot spots which can damage the heating wire. The total free area to be heated needs reducing by 10%. This allows for the 100mm space around the perimeter of the room and variations due to the shape of the room.

It is always best to have a little less cable than some left over.

Decide on the position of the thermostat, this must be situated outside of a bathroom. The cold connection lead(s) of the heater(s) will normally start from this point. If more than one heating cable is to be controlled by one thermostat, these can be joined in parallel within a low level junction box.

When decided on this position (including the positions of the cable(s)), a groove should be cut into the floor to accommodate the floor sensor tube & the thicker cold end of the heating wire. A groove will also be required to accommodate the termination joint at the other end of the cable.

Before starting to fix the cable into position, with a permanent marker, mark out areas on the floor where units and fixtures will be fitted. Then mark out on the floor the space around the perimeter of the room. Also mark the spacing intervals for the wire, recommended on P9 from the start point around the perimeter of the room.

Testing the heater(s)

One of the most important steps to be taken when installing the cable, is the testing process. You must ensure that the cable is tested **BEFORE, DURING & AFTER** installation using a Multi-meter.

The resistance (Ohms) of each cable should be measured from the live (brown) wire to the neutral (blue) wire. Your multi-meter should be set to range of 0-2k Ω (Ohms.) The measured value should then be checked against the table on the right. The value should be within -5% to +10%.

If you get any different readings contact Total Tiles immediately on 08444876548 or email enquiries@totaltiles.co.uk

The insulation resistance must also be checked. This should be checked with a digital insulation tester. The resistance should be tested between the live (brown) wire and the earth (unsheathed) wire and also between the neutral (blue) wire and the earth (unsheathed.) Both should read >500M Ohms.

These insulation readings are required to be carried out as per BS7671.

The insulation resistance can also be checked (excluding final tests) with a digital multi-meter. The meter should be set to the highest resistance range. The reading should show Infinity / Open Circuit.

When checking resistance, make sure your hands do not touch the meter's probes as the measurement will include your internal body resistance making the reading inaccurate.

Both Resistance Tests & Insulation Resistance Tests should be carried out at the following stages. The results of which should be recorded on your warranty card.

1. Before the cable is laid to ensure it has not been damaged in transit.
2. After the cable is installed to ensure it has not been accidentally damaged whilst cutting the mesh.
3. After the cable has been covered in levelling compound, but before tiling.
4. After the tiles have been installed

Testing the floor sensor

The floor sensor should also be tested before, during & after fitting. This can be checked with a multi-meter set to a range of 0-200k Ω (Ohm) The reading should be 9-25K Ohms.

ALL TEST RESULTS MUST BE RECORDED ON P17 & P19

Testing Reference Guide

Heating cable values

Catalogue Number	Cable Length (m)	Heated Area M ² 150w/m ² 80mm Spacing	Heated Area M ² 200w/m ² 60mm Spacing	Heated Area M ² 100w/m ² 120mm Spacing	Output (Watts)	Current (Amps)	Resistance (Ohms)
MiniCable/12-150	12.5	1.0	0.75	1.50	150	0.7	352.7
MiniCable/12-225	18.8	1.5	1.13	2.25	225	1	235.1
MiniCable/12-300	25.0	2.0	1.50	3.00	300	1.3	176.3
MiniCable/12-375	31.3	2.5	1.88	3.75	375	1.6	141.1
MiniCable/12-450	37.5	3.0	2.25	4.50	450	2	117.6
MiniCable/12-525	43.8	3.5	2.63	5.25	525	2.3	100.8
MiniCable/12-600	50.0	4.0	3.00	6.00	600	2.6	88.2
MiniCable/12-675	56.3	4.5	3.38	6.75	675	2.9	78.4
MiniCable/12-750	62.5	5.0	3.75	7.50	750	3.3	70.5
MiniCable/12-900	75.0	6.0	4.50	9.00	900	3.9	58.8
MiniCable/12-1050	87.5	7.0	5.25	10.50	1050	4.6	50.4
MiniCable/12-1200	100.0	8.0	6.00	12.00	1200	5.2	44.1
MiniCable/12-1350	112.5	9.0	6.75	13.50	1350	5.9	39.2
MiniCable/12-1500	125.0	10	7.50	15.00	1500	6.5	35.3
MiniCable/12-1800	150.0	12	9.00	18.00	1800	7.8	29.4

Heat Cable specifications

Cable Construction:	Twin conductor 100% Armoured earth coverage
Rated Voltage:	230V
Output:	12w/m (length)
Cable spacing:	150w/m ² -80mm 200w/m ² -60mm 100w/m ² -120mm
Cable Diameter:	3.6mm
Conductor Insulation:	fluoropolymer
Outer Insulation:	PVC
Max. Ambient Temp.:	85°F (30°C)
Min. Installation Temp.:	40°F (5°C)
Cold lead	2-wire plus ground braid; 2.5m length

Heating Installation

Installation of the floor sensor

The floor sensor needs to be installed within a flexible conduit. The sensor should be situated 250-300mm away from the wall **and centred between two heating wires**. The sensor should also not be installed close to any other heat source, doors or fixed items. Ensure the sensor tube has a gradual bend when it enters floor level. This will ensure that if the sensor ever needs replacing, it can be easily inserted. Use duct tape to cover the end of the tube.

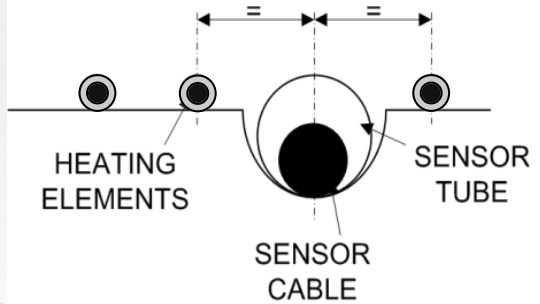
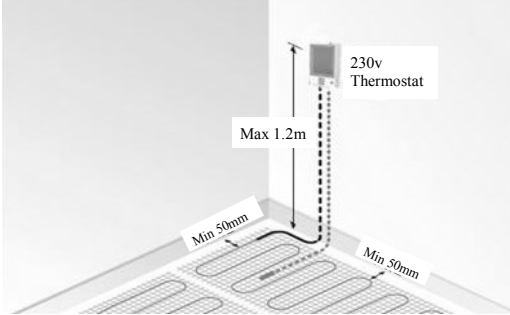

Heating mat installation

1 Priming the floor



Ensure the floor is clean, dry, smooth, flat and free from dust or grease. Surfaces such as insulation boards and other non porous floors including those that have already be sealed or primed should not be further treated with the thermal primer. Contact your tile supplier for further details regarding your specific project. Porous surfaces such as concrete should have one even coat of the thermal primer applied with a roller.

2 Marking the cable spacing

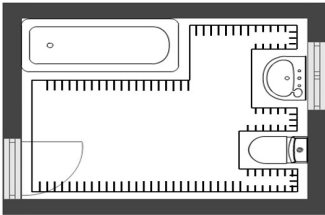

Mark the 100mm (Min 50mm if necessary) space around the perimeter of the room. Refer to the spacing intervals on P9 and mark this interval from the start point around the perimeter of the room.

3 Plan the cable layout

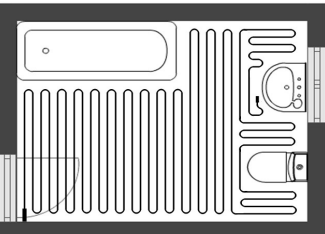

Plan the layout of the cable ensuring that all areas are covered, remembering that the wires must not cross (including sensor) and that there must be a minimum 50mm gap between the wires. The main area should be covered by laying the cable back & forth across the room. There are many different ways to cover irregular areas, including the example shown on the left. Ensure that the bends of the cable are sweeping and not tight.

It is highly recommended to take photographs of the installed cable before fitting the flooring

Heating Installation

Key considerations on heating cable layout

- Minimum distance between heating wires - 50mm
- Maximum distance between heating wires - 120mm (Any greater can cause cold spots)
- Sweeping not tight curves made with heating wire.
- Minimum distance between a heating wire and any object such as a pipe or wall - 50mm
- Only install the cable in temperatures above 5°C
- Do not install under fixed items unless a 60mm free flow air gap can be maintained.
- Do not cross any heating wires.
- Do not cross the heating wire with the sensor wire.
- Ensure the sensor is installed dead centre between two heating wires.
- Ensure supply lead joint & termination joint are both situated under the floor to be tiled.
- Test the heat mat BEFORE laying the tiles.
- Contact Total Tiles immediately if any test results show an issue with the heater.

Fixing the heating cable to the floor

The cable can be fixed to the floor using either tape or metal strapping:

1 Tape Method



When first laying out the heating cable, fix the end of each length of cable with a small 25mm (1inch) strip of tape. Once the cable has all been laid out to the plan, some adjustments may be necessary

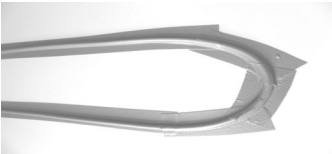

Once the position of all the cable has been finalised, the entire length of cable should be covered in tape. When applying a length of tape, run your forefinger and thumb along the length of the wire ensuring the tape hugs the wire and there are no air spaces under the tape.

2 Metal Strapping method

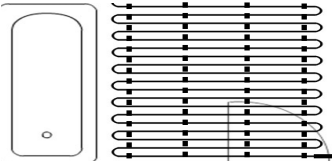

Before starting to fit the cable, fix the metal strapping at a 90° angle to the planned cable lengths at approx 500mm intervals. The metal strapping can be fixed to the floor using tacks, adhesive or double sided tape.

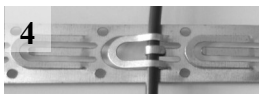

Lay the cable out following the plan. To clip the cable into the strapping:

1. Lift the large hook.
2. Place the cable under the large hook.
3. Wrap the small hook around the cable.
4. Push the large hook back over the Cable.



Floor Tile Installation

There are two main considerations when tiling over the heat cable:

1. Ensure the cable is fully encapsulated. The levelling compound or tile adhesive should fully cover the wire, leaving no air pockets around it.
2. Take care not to damage the cable with the use of metal trowels. The use of plastic trowels is recommended.

To fix tiles, a single or two step method can be selected.

Single Step Method

Using a suitable flexible tile adhesive, tiling can be carried out as a single operation directly on top of the heating cable. Allow a depth of adhesive sufficient to lay the tile and fully encapsulate the heating element with no air gaps.

An S1 grade adhesive is required for installations with a concrete subfloor. A S2 grade adhesive is required for installations with a timber subfloor.

Two Step Method

Apply a layer of flexible self levelling compound to cover the cable & encapsulate the heating elements with no air gaps. Allow to cure in accordance with the manufacturers instructions.

This will provide protection to the heat cable and give a level surface to tile on to. Next apply the tiles using a flexible tile adhesive in the normal manner.

(Recommended method)

Ensure that the correct types of adhesive, grout & levelling compound products are selected. These should be compatible with under floor heating and selected based upon the subfloor and tile type.

Recommendations from the manufacturers of these products must be followed.

Tiling should be carried out in accordance to the standards specified in BS 5385 and in accordance with the tile manufactures recommendations.

Do not store tiles or heavy objects on the heat cable whilst tiling. Also do not cut or prepare tiles on top of the heating cable.

Wait for a minimum of 14 days following tiling to allow the adhesive to fully cure before switching on the system. When the system is switched on, the temperature should be slowly raised over a number of days.

Safety - Electrical Considerations

As with all electrical work governed by Part P regulations, all mains electrical connections must be undertaken by a certified electrician. All work must conform to current IEE Wiring Regulations.

Supply Circuit

- BodenWärme heating systems are designed for operation at 230V 50Hz.
- The heating system **MUST** be protected by a 30mA RCD (Residual Current Device) *This can be situated within the consumer unit or via a dedicated RCD fused spur.*
- Ensure the total current (Amps) of your heating system and other appliances connected to the circuit do not exceed the current capacity of the circuit. *Normal ring circuits are rated at 13A and loads within this rating can be taken via a single 13A fused spur.*
- The thermostat must be connected to the main electrical supply via a switched fused spur. The spur must have contact separation in all poles that will provide full disconnection under overvoltage category III conditions.

Thermostat Connection

- BodenWärme thermostats have a rating of 16Amps. We recommend a maximum area of 20m² (150w/m²) to be controlled by one thermostat. Any area greater than this should be split into separate zones (different heat mats) and controlled by more than one thermostat. Alternatively a contactor can be installed to switch the load.
- The thermostat should be installed within the room or area to be heated. **However**, the thermostat should be situated outside the room if the room contains a bath, shower, sauna hot-tub or swimming pool. In these cases the thermostat should be located on the outside of the heated rooms internal wall, as close as possible to the heating power supply cables.
- The wiring from the heater to the thermostat should be protected by conduit or plastic trunking. The thermostat should be installed in a 45mm depth back box.

System Configuration

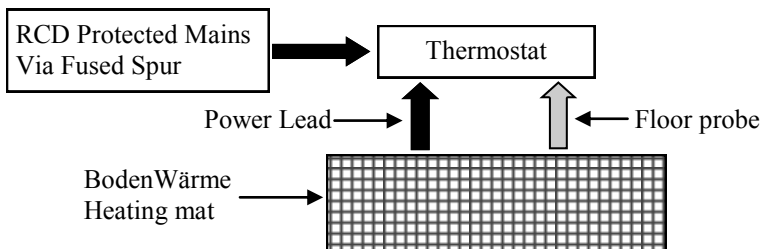

If more than two heaters are being installed, a junction box will be required to connect the heaters with the thermostat

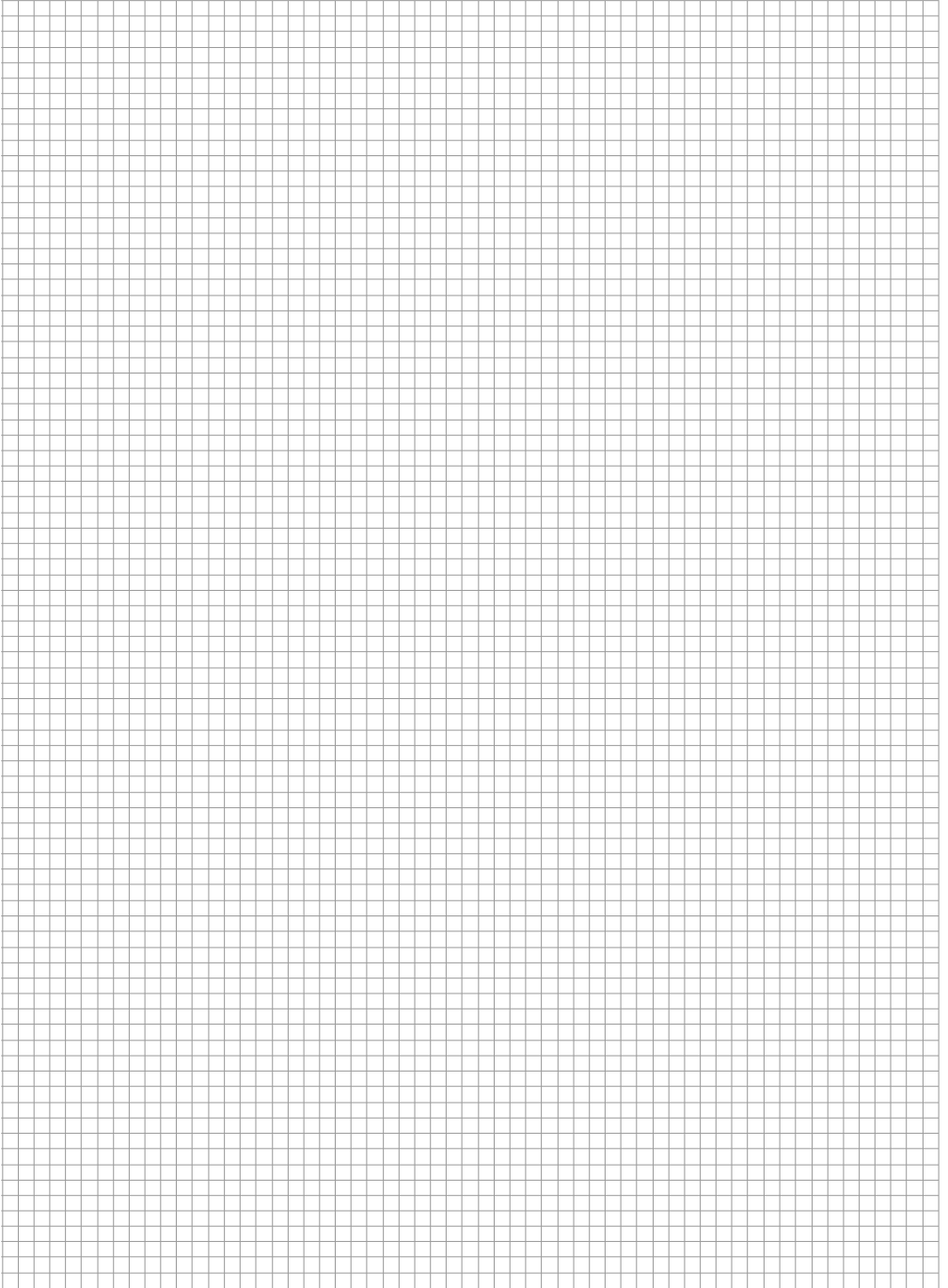

Attach Photo's Here

Attach Photo's Here

Attach Photo's Here

Attach Photo's Here

Attach Photo's Here

Warranty

BodenWärme Undertile Heating is guaranteed by Total Tiles Ltd to be free from defects in materials and workmanship under normal use and maintenance, for a period of 25 years subject to the limitations and conditions described below.

The warranty is valid assuming the following conditions are met:

1. The heater is correctly installed according to the instructions laid out in this manual.
2. The heating system must be registered with Total Tiles Ltd within 60 days after purchase. The registration details can be found on the last page of this instruction manual. Original receipts / invoice should be kept as proof of purchase in case of a claim. Registration confirmation from Total Tiles will also be required.
3. The heater must be earthed and protected with a 30mA RCD & appropriate over current protection at all times.
4. The heater must be controlled by a BodenWärme approved thermostat & floor temperature sensor, installed according to the instructions included.
(Thermostat's and floor sensors are guaranteed for a period of one year)

Total Tiles Ltd are NOT responsible for:

1. Damage or repairs required as a consequence of faulty installation or application.
2. Consequential & secondary costs or damages linked to the defect or replacement of the heating, including the dismantling of the defective product and the installation of a new product.
3. Damage as a result of floods, fires, winds, lightning, accidents, corrosive atmosphere or other conditions beyond the control of Total Tiles Ltd.
4. Use of components or accessories not compatible with BodenWärme products.
5. Products installed outside of the UK.
6. Parts not supplied or designated by Total Tiles Ltd.
7. Damage or repairs caused by improper use, maintenance, operation or servicing.
8. Failure to start due to interruption and / or inadequate electrical service.
9. Any damage caused by frozen or broken water pipes in the event of equipment failure.
10. Changes in the appearance of the product that does not affect its performance.

During the guarantee period Total Tiles will arrange for the repair or (at its discretion) replacement or refund of the cost of the heating. The cost of repair or product replacement is your only remedy under this guarantee which does not affect your statutory rights. Such cost does not extend to any cost other than the direct cost or replacement by Total Tiles and does not extend to costs of relaying, replacing, or repairing any floor covering or floor.

If the heater fails due to damage caused during installation or tiling, this guarantee does not apply, therefore it is important to test the heating as detailed on P8.

In the event of suspected product failure Total Tiles will arrange for the necessary survey work. As there is only a 0.0004% chance of product failure the likely outcome is the identification of an installation fault. Due to this, the cost of the survey will be the liability of the customer until such a time a product fault is identified.

TOTAL TILES LTD SHALL IN NO EVENT BE LIABLE FOR ANY LOSS OR DAMAGES OF ANY KIND, INCLUDING ANY INCIDENTAL OR CONSEQUENTIAL DAMAGES RESULTING, DIRECTLY OR INDIRECTLY, FROM ANY BREACH OF ANY WARRANTY, EXPRESS OR IMPLIED, OR ANY OTHER FAILURE OF THIS PRODUCT. THIS WARRANTY IS THE ONLY EXPRESS WARRANTY TOTAL TILES MAKES ON THIS PRODUCT. THE DURATION OF ANY IMPLIED WARRANTIES, INCLUDING THE WARRANTIES OF MERCHANTABILITY AND FITNESS FOR A PARTICULAR PURPOSE, IS HEREBY LIMITED TO THE TWENTY FIVE YEAR DURATION OF THIS WARRANTY.

Consumer unit notice

The following notice should be situated in a visible location close to the consumer unit.

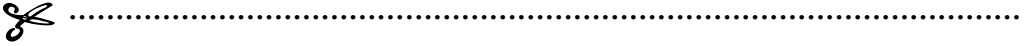

BodenWärme Floor Heating

Heater Location _____

Total Wattage _____

CAUTION

Radiant Floor Heating Systems Installed.
Warning—Risk of electric shock.
Electric wiring and heating panels contained below the floor. Do not penetrate with nails, screws or similar devices. Do not restrict the thermal emission of the floor

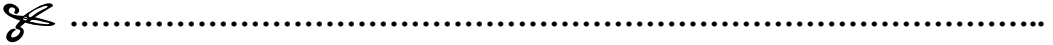
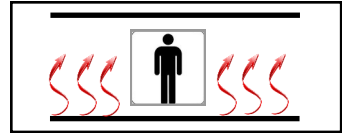

Test Results

Room heating fitted in	Model Number	Batch Number	Installation Date
<i>e.g. Bathroom</i>	<i>E.g. MiniCable/12-150</i>	<i>E.g. 8600017</i>	
Resistance Reading Before fitting cable	Resistance Reading After fitting cable	Resistance Reading After levelling, before tiling	Resistance Reading After tiling
Insulation Resistance Reading Before fitting cable	Insulation Resistance Reading After fitting cable	Insulation Resistance Reading After levelling, Before tiling	Insulation Resistance Reading After tiling



Disclaimer

Total Tiles Ltd can accept no responsibility for possible errors in catalogues, brochures, other printed materials and website information. Total Tiles reserve the right to alter products without notice. This also applies to products already on order providing that such alteration can be made without subsequent changes being necessary in specifications already agreed upon. All trade marks in this material are the property of the respective companies. All rights reserved.

Warranty (Return to retailer)

Owner's Name:			
Owner's Address:			
Postcode:		Telephone Number:	
E-mail:			
Installer Name:			
Installer's Telephone Number:			
Installer's Signature:			

I hereby confirm that I have read & understood the contents of the installation manual and that the heater(s) have been installed in accordance with all specifications detailed within. I Acknowledge that no claim can be brought against the manufacturer or its agents for any consequential loss or damage whatsoever. I confirm that the heater(s) was working prior to tiling.

Electrician Name:			
Electrician's Telephone Number:			
Organisation Registered With:		Registration Number:	
Tiler's Name:			
Tiler's Telephone Number:			
Date of Purchase:		Purchased from:	
Model Number:		Batch Number:	
Type Of Room:		Completion date:	

Room heating fitted in	Model Number	Batch Number	Installation Date
<i>e.g. Bathroom</i>	<i>E.g. MinimatD / 150-600-4.0</i>	<i>E.g. 8600017</i>	
Resistance Reading Before fitting mat	Resistance Reading After fitting mat	Resistance Reading After levelling, before tiling	Resistance Reading After tiling
Insulation Resistance Reading Before fitting mat	Insulation Resistance Reading After fitting mat	Insulation Resistance Reading After levelling, Before tiling	Insulation Resistance Reading After tiling

Warranty (Return to retailer)

The form overleaf must be filled out completely, otherwise you may invalidate your warranty.

Once completed, please return by one of the methods below.

Post

Total Tiles Ltd
17 Arkwright Road
Hadleigh Road Industrial Estate
Ipswich
Suffolk
IP2 0UB

Fax

08442723249

E-mail scanned copy

warranty@totaltiles.co.uk